

Corky,

a Pint-Sized Sailer

You needn't worry when Junior decides to play Robinson Crusoe in this sailboat. It can't sink



600 x 16 size was used on this one.

Saw the various wooden parts to shape from the $\frac{3}{4}$ x 8 in. white pine. Then drill holes for the rudder post and mast. Do not drill the bottom piece for the mast, only the mast step. Next fasten the pieces together with $1\frac{1}{2}$ in. #10 fh brass wood screws as indicated. Two old G. I. belts will serve for the innertube straps. They should be screwed in place with two $\frac{3}{4}$ -in. #10 rh brass screws and brass washers. Bolt an awning cleat to the forward deck for the halyard. The forward upper strap may be fastened to the underside of the deck using the same type bolts as were used for the deck cleat.

The mast and boom are made from broom handles. For the halyard block use an awning pulley fastened to a large screw eye. The boom fastening is made from two large screw eyes hooked together. The rudder post is also from a broom handle. Use $\frac{3}{4}$ in. Masonite or $\frac{1}{2}$ in. plywood for the rudder blade, and fasten it to the rudder post

HERE is a non-sinkable sailboat for the youngsters that can be made easily in one or two evenings in the workshop. Mother can help on this one too; have her sew up the sail while you are making the hull parts. Most any of the standard sized innertubes will fit the frame for the sides of the boat. A

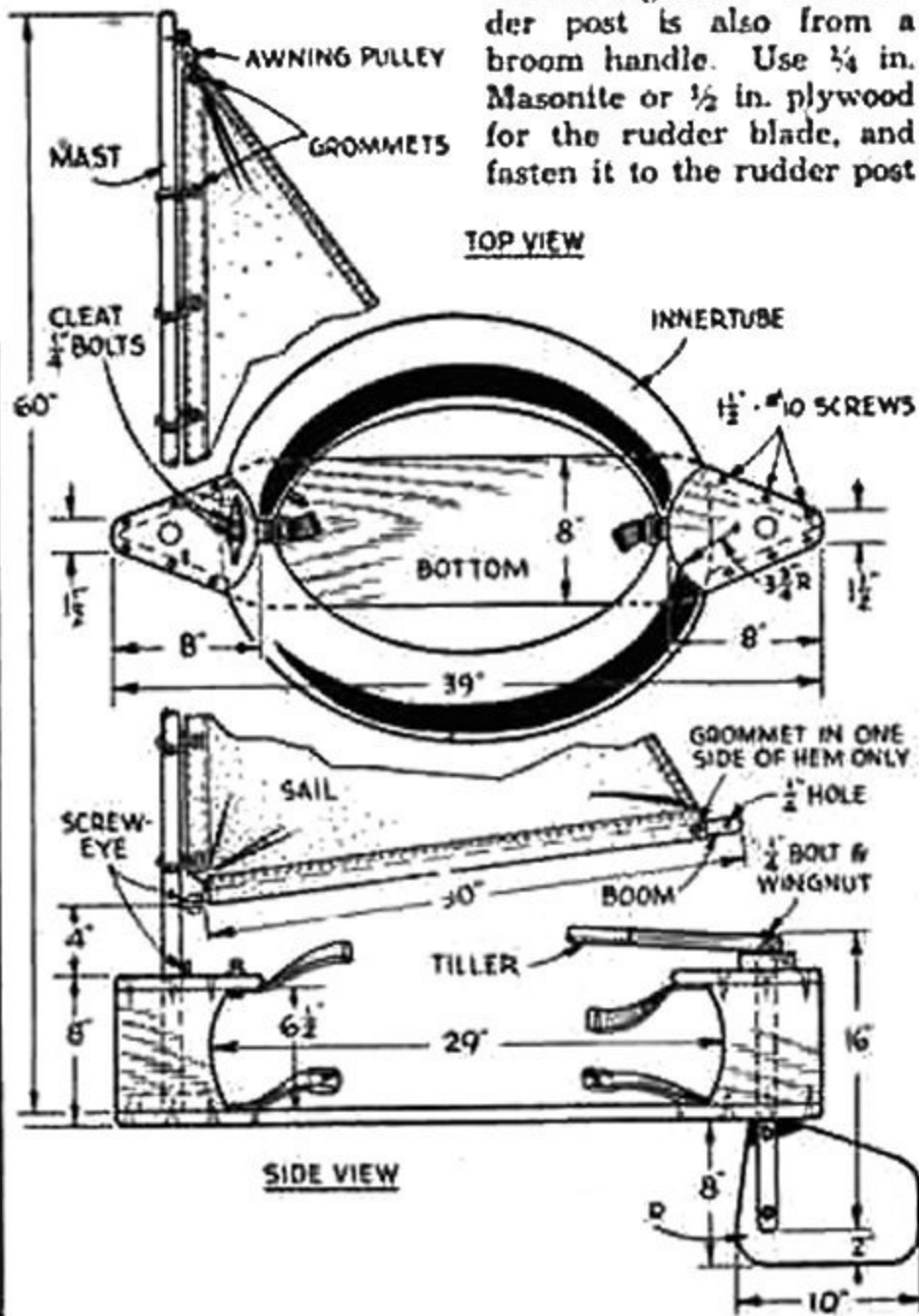
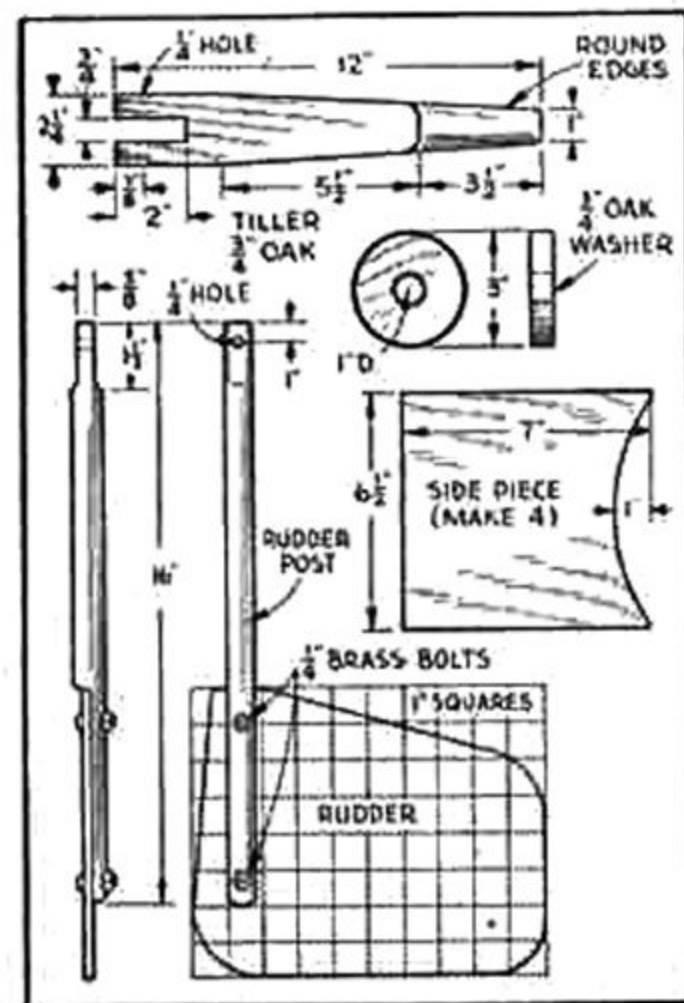

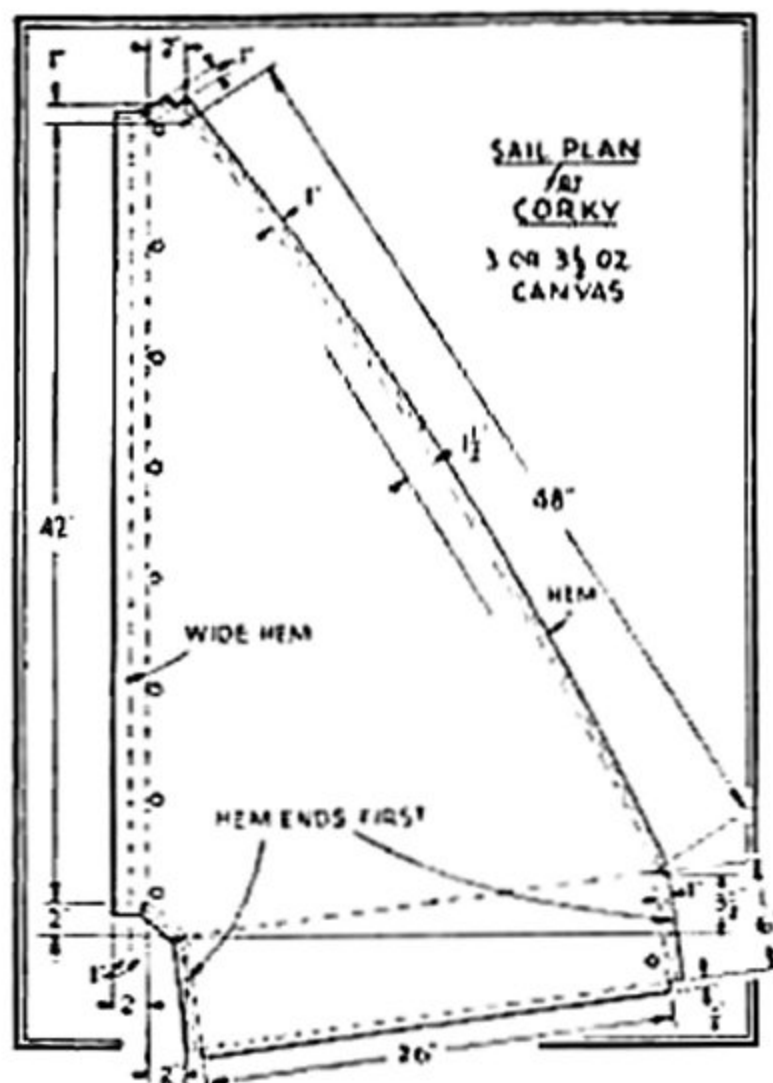

SAIL PLAN
FOR
CORKY
3 OR 3 1/2 OZ
CANVAS

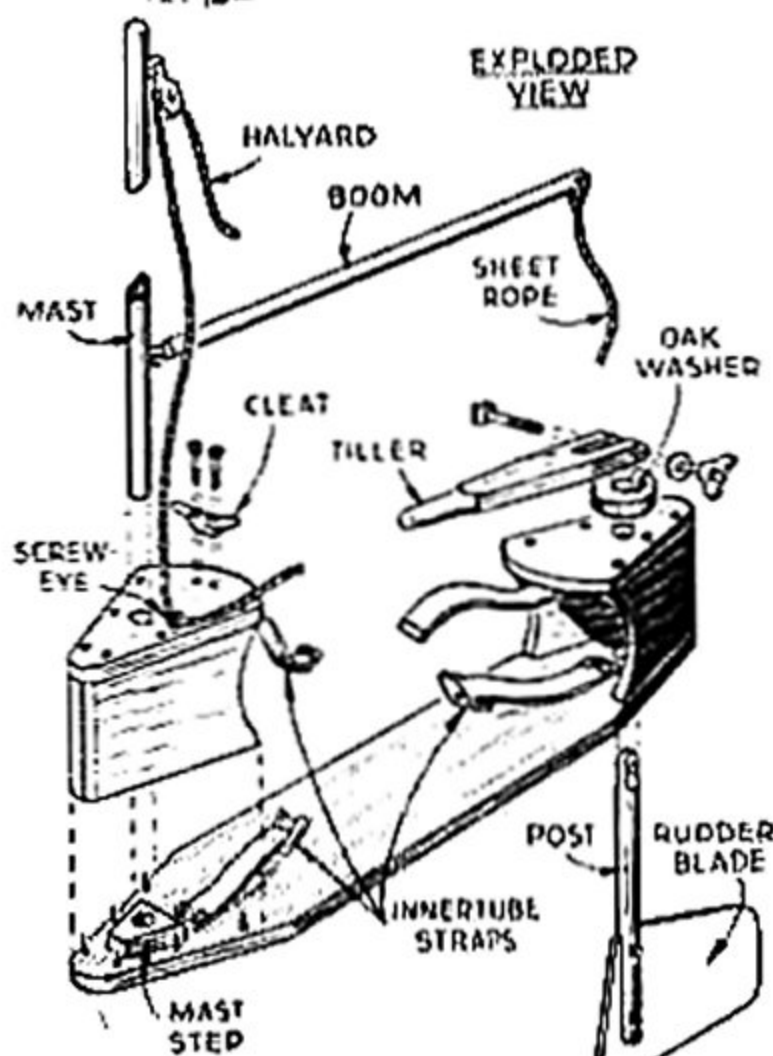

with two $\frac{3}{4}$ in. bolts. Notch the rudder post as shown to take the blade. Make up the tiller from a piece of $\frac{3}{4}$ in. oak fastened to the rudder post with one $\frac{3}{4}$ in. bolt and wingnut.

For the one-piece sail, a piece of 3 or $3\frac{1}{2}$ oz. canvas, 48 in. long and a yard wide will be

MATERIALS LIST—CORKY

HULL 1 inner tube—600 x 18 or similar
 $1\frac{1}{2}$ " x 8" x 6" white pine
MAST 1—60" broom handle
BOOM AND RUDDER POST 1—48" broom handle
TILLER 1— $3\frac{1}{4}$ " x $2\frac{1}{4}$ " x 12" oak
RUDDER BLADE 1— $1\frac{1}{4}$ " x 8" x 10" Masonite or $\frac{3}{8}$ " plywood

FASTENINGS

2 1/2 doz. $1\frac{1}{2}$ " #10 fh brass screws
 4— $\frac{1}{4}$ " brass bolts $1\frac{1}{2}$ " long, with washers
 1— $\frac{3}{4}$ " brass bolt $2\frac{1}{2}$ " long with wingnut
 8— $\frac{3}{4}$ " #10 fh brass screws and washers
 2 G. I. belts (for strapping inner tube in place)

SAIL

$1\frac{1}{2}$ yds. 3 or $3\frac{1}{2}$ oz. duck, 36" wide
 10 grommets

FITTINGS

7 shower curtain rings
 1 small owning cleat
 1 small owning pulley

needed. First lay out a pattern on a sheet of wrapping paper. Pin this pattern to the canvas and cut to shape. The foot of the sail should have a wide seam to take the grommets for the sail rings. Metal shower curtain rings will make ideal sail rings. Ten feet of $\frac{1}{4}$ in. clothesline for the halyard and five feet for the sheet rope are all that is needed to complete this miniature sailboat, which will mean happy sailing for Junior.

Stuck with One Oar?

IF YOU are caught out on open water with only one oar try sculling your way back to shore. Sculling is a method of propelling a boat that fishermen have used for centuries. Sculling a boat is easy, but you will require a little practice to become proficient.

First place your self in the stern of the row boat. Grasp the oar so that one hand is on the handle and the other about halfway down on the shaft. Put the blade on the water until it is about $\frac{3}{4}$ submerged, holding it at a 45° angle. Using the lower hand as the fulcrum, move the handle back and forth, twisting the oar at the end of each stroke with the upper hand so that blade cuts into the water forcing the boat ahead; action is similar to that of a propeller blade in water. If boat has a notch for a steering oar, use that notch as the fulcrum.—D. M. S.

