

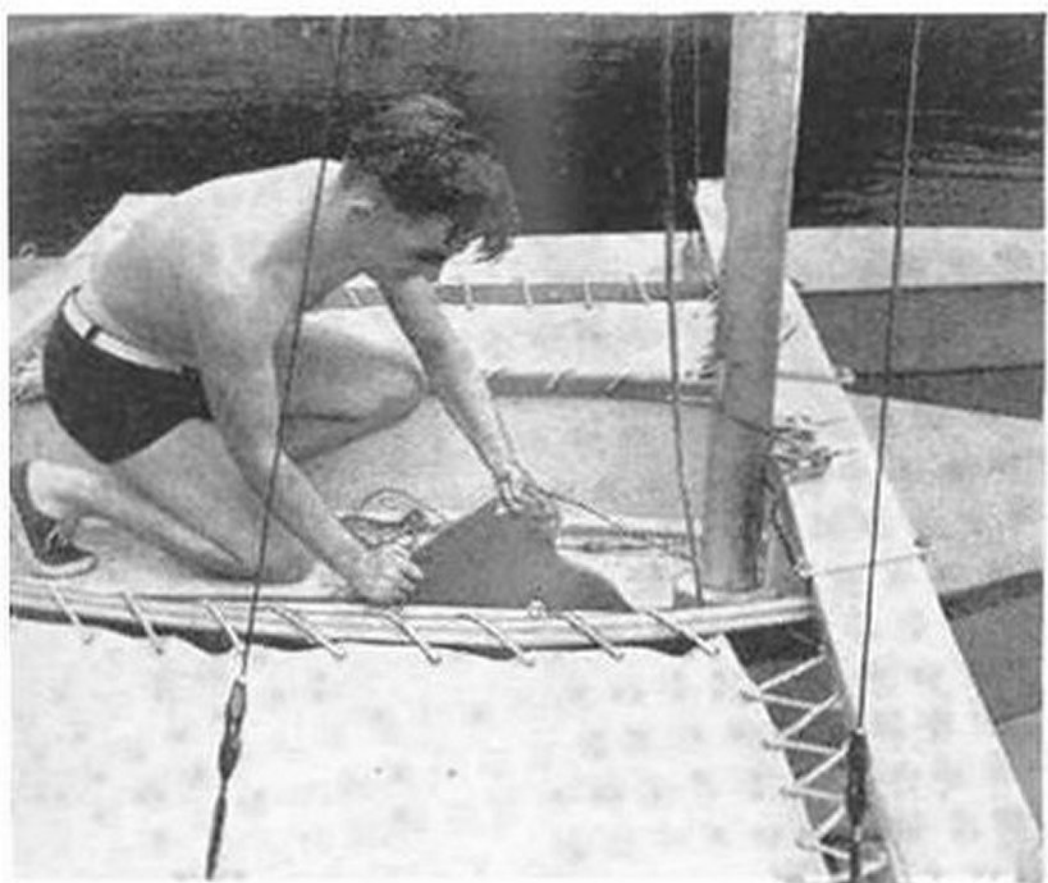

Above, stern view of Trimaran shows wooden bracket just aft of cockpit. This permits emergency mounting of outboard motor on starboard side of center hull



Raising the plywood centerboard, above, cuts draft of main hull to a few inches. Below, lightweight aluminum boom is easy to handle when hoisting main-sail. Note cable stays anchored to cockpit supports



Build this 20-ft. TRIMARAN

DESIGNED by Commodore Victor Tchetchet of the International Multihulled Boat Racing Association, Trimaran combines the thrills of a conventional sailboat with an exceptional rate of speed, maximum safety and unusual ease of handling. In a spanking wind, the sleek hull with its outriggers skims over the water at speeds as high as 22 m.p.h., and in a hardly perceptible breeze, when other sailboats are without steerageway, she moves along at a surprising speed. Capsizing is next to impossible because of the buoyancy of the outrigger pontoons. Even a wind approaching gale force would be more likely to blow out the sail or snap the mast than capsize the craft. But, while the rugged construction and "3 hull" design permit Trimaran to withstand high winds and heavy seas in an emergency, it must be remembered that she still is a small boat and sailing should be confined to protected waters.

The main hull and pontoons are built by covering wooden frames, spaced 12 in. apart, with $\frac{1}{4}$ -in. waterproof plywood. First, make the 20 frames for the hull to the dimensions given in the table of offsets, Fig. 2. Join the frame members with waterproof glue and

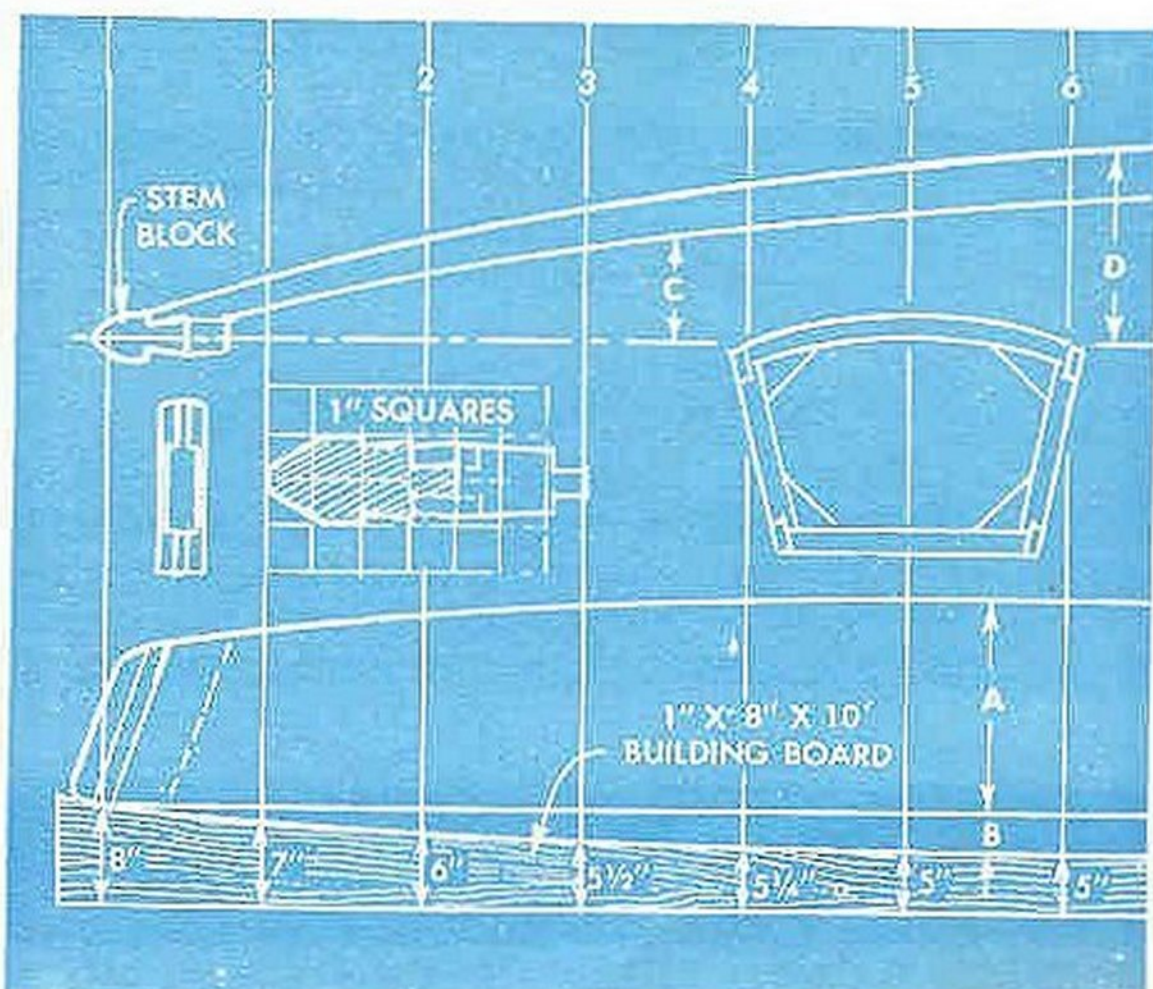
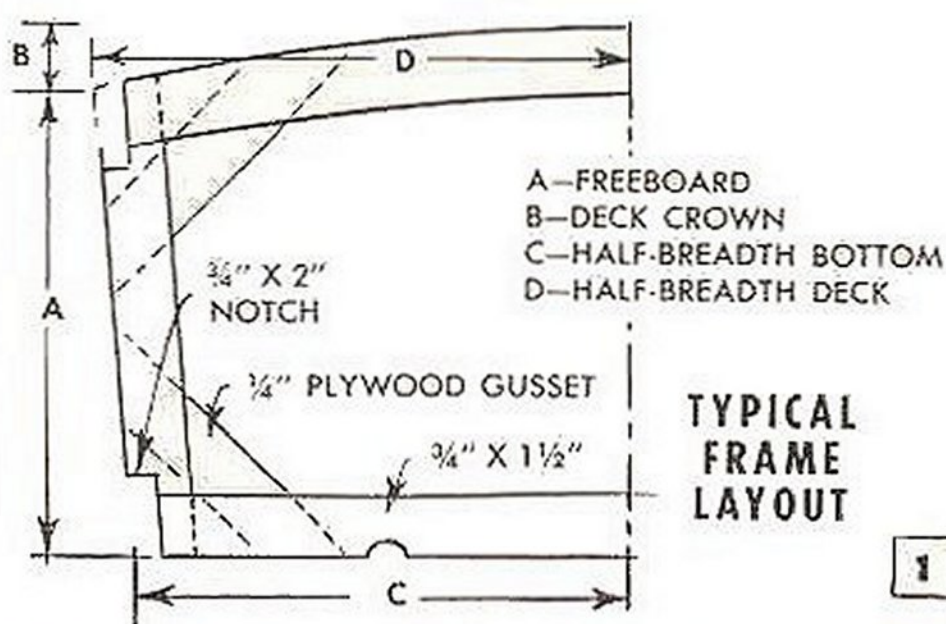

TRIMARAN

reinforce them with plywood gussets, which are glued and nailed to the faces of adjacent members, as in Fig. 1. When building Trimaran, use monel-metal screw-type nails throughout. Note that five frames, stations 8 to 12, must be made in two parts to permit installing the centerboard trunk. Fig. 4 shows how these particular frames are put together.

After assembling all the hull frames, make a building board from 1 x 8-in. stock, cutting the contour of the top edge of the board to conform with the profile view, Fig. 3. Support the building board on sawhorses, Fig. 4, and temporarily nail the frames in position on the board, spacing them 1 ft. apart on centers. Assemble and install the centerboard trunk, as in the upper details. Then glue and nail the chine and sheer battens in the notches cut in the corners of the frames. Fair the chines and sheers into the stem and stern blocks, planing the battens flush with the frame surfaces. The centerboard trunk is made up of two pieces of 1/4-in. plywood mounted on two oak up-rights. A 1-in.-sq. cleat along each side of the trunk 1/2 in. from the bottom edge provides a surface for bolting and gluing the plywood bottom around the trunk. Cotton calking laid in glue on adjacent sides of the cleat between the bottom and the trunk assures a watertight joint.

To plank the hull, cut the plywood for

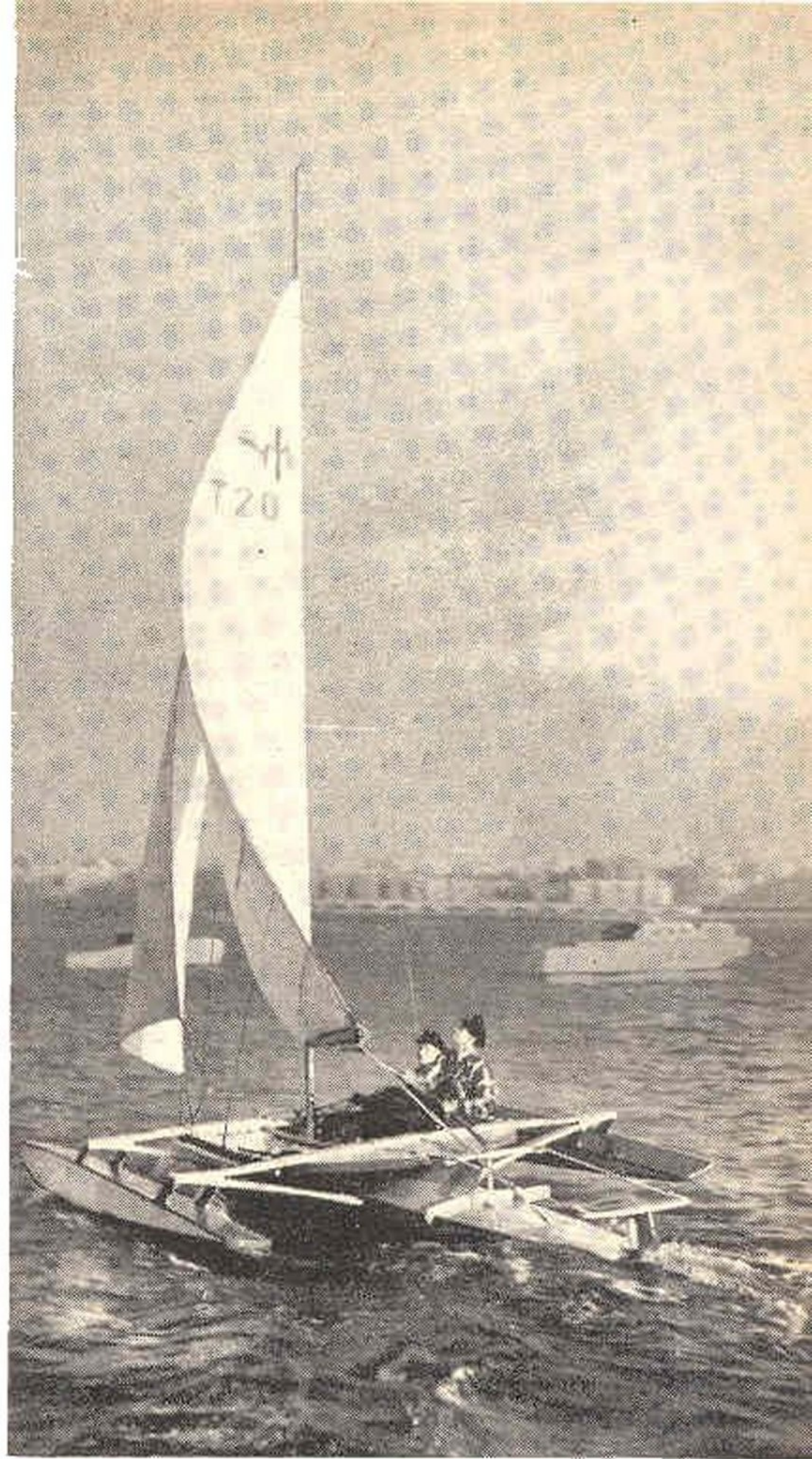

2																				
TABLE OF OFFSETS																				
MAIN HULL (DIMENSIONS IN INCHES)																				
STATIONS	1	2	3	4	5	6	7	8	9	10	11	12	13	14	15	16	17	18	19	20
HALF BREADTHS FOR BOTTOM	2 1/4	4 3/4	6 3/4	8 1/2	9 3/4	10 3/4	11 1/2	11 7/8	12	12	12	12	12	11 7/8	11 3/8	11 3/8	10 3/4	10	9 1/4	8 1/2
HALF BREADTHS FOR DECK	4	7 1/4	10	12 1/2	13 1/2	14 1/4	14 7/8	15	15	14 3/4	14 1/2	14 1/8	13 5/8	13 1/8	12 1/2	11 3/4	11	10	9 1/4	8 1/2
FREEBOARD	13 1/4	14 7/8	15	15 1/2	15 3/4	15 3/4	15 3/8	15 1/2	15 1/4	15	14 7/8	14 1/2	14	13 3/8	12 3/8	11 1/8	9 5/8	7 3/4	5 3/4	2 1/2
DECK CROWN	1	1 3/4	2 1/8	2 3/4	3	3	3	3	2 7/8	2 3/4	2 1/2	2 1/4	2	1 3/4	1 5/8	1 1/2	1 1/2	1 1/2	1 1/2	1 1/2

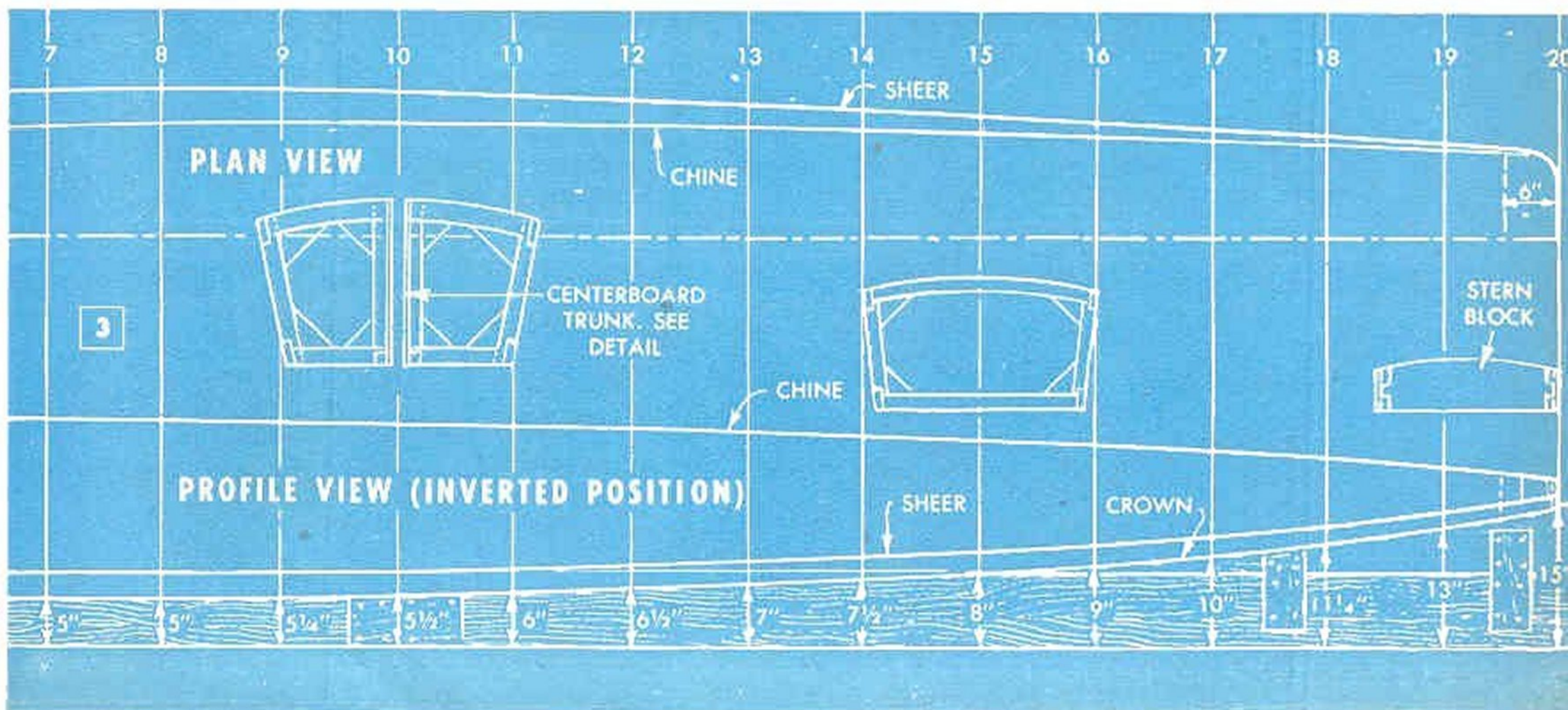

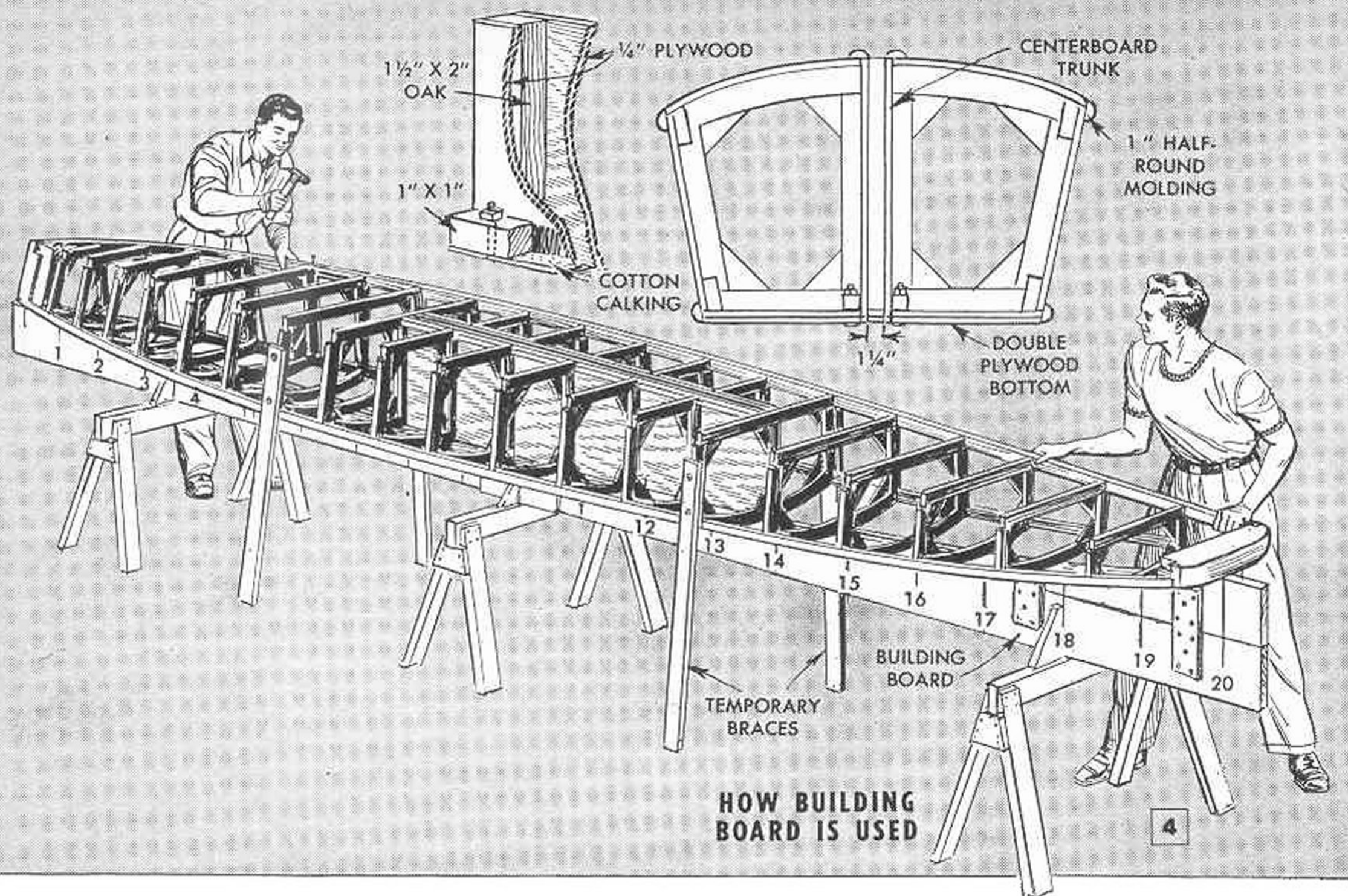

the sides slightly oversize. Coat contacting surfaces of the chines and frames with waterproof (marine) glue and fasten the plywood in place with monel nails spaced 2 in. apart. Then clamp the plywood to the chines and frames. When the glue has dried, cut off the overhanging edges of the plywood and plane flush with the battens. The bottom is covered with two layers of $\frac{1}{4}$ -in. plywood, the pieces being cut a little oversize and slotted where they fit over the centerboard trunk. To assure watertight joints along the chines and around the trunk opening, cotton tape is laid in a thick coating of marine glue which is applied to all contacting surfaces. Then the plywood is laid in the glue and nailed as before. The second layer of plywood is merely glued to

the first one. When planking the boat, you can add strength by making sure that the plywood joints on opposite sides of the hull fall on different frames. The deck is covered with one layer of $\frac{1}{4}$ -in. plywood bent over the crown. After the deck is in place, the edges of the plywood are trimmed flush with the sides and the joints are covered with 1-in. half-round molding.

Construction of the main hull is completed by adding the cockpit, the sides of which are glued and nailed to a curved chine fastened directly to the plywood deck, Figs. 8 and 9. A series of holes, drilled near the deck line in the aft portions of the cockpit sides, provides a self-bailing feature to drain off spray. Both fore and aft sections of the cockpit are covered with plywood.

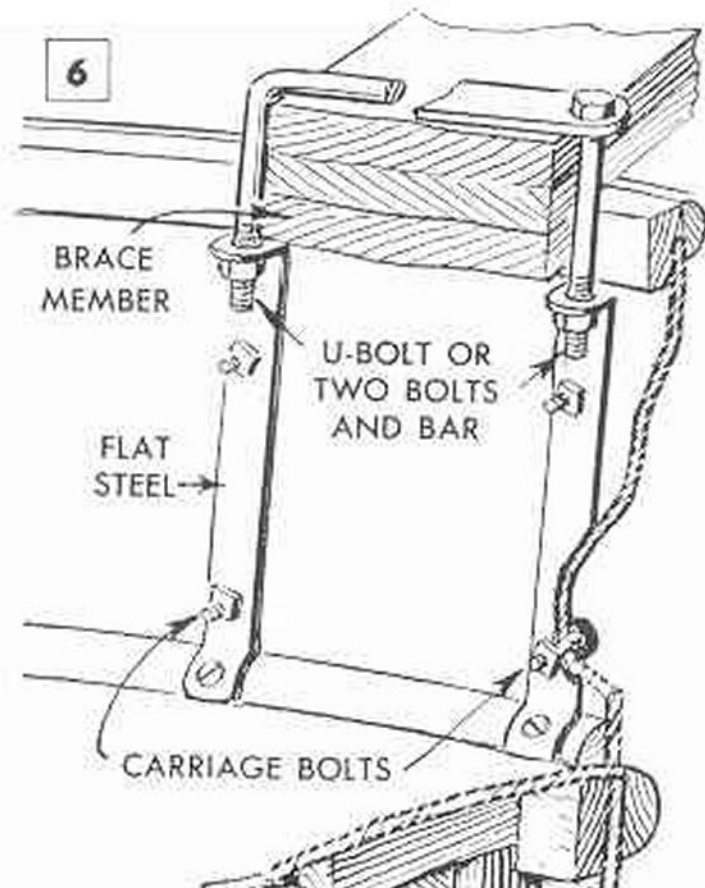
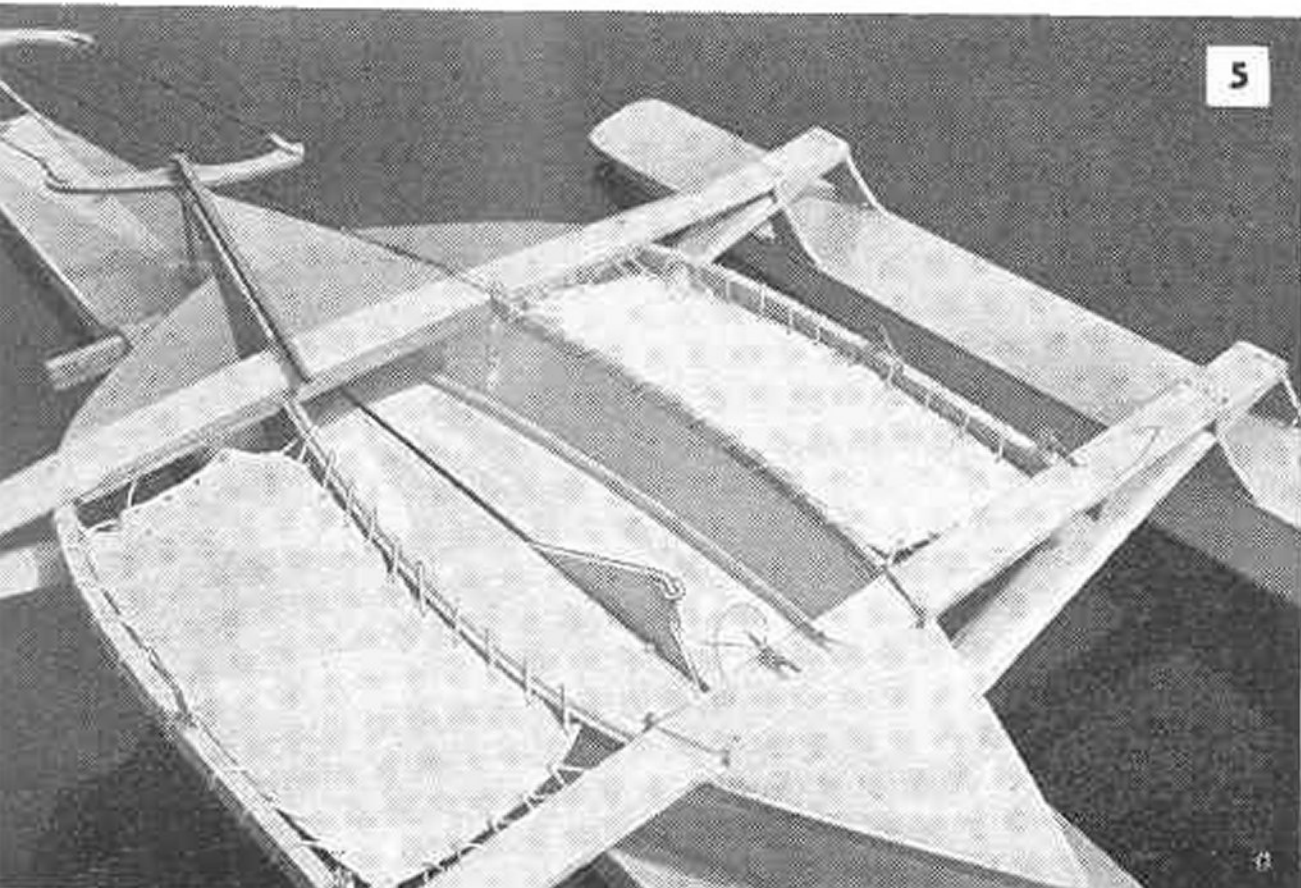

Construction of the two pontoons is similar to that of the main hull. See the table of offsets, Fig. 10, for the dimensions and Figs. 11 and 17 for the plan and profile views. As the corners of the pontoon frames are square, they can be assembled quickly in a jig made by nailing two boards to the floor or bench top at right angles to each other. Note in Fig. 21 how the pontoons are reinforced at the points where the crossbeam hangers are attached. The frames are left open at the corners for $\frac{3}{4}$ -in.-sq. chines, parts being joined only by the plywood gussets. The frames are assembled on a building board which is cut to dimensions given in the table of offsets opposite the heading, "rise of chine floor to bottom." The $\frac{1}{4}$ -in.-plywood sides can be beveled and glued and nailed together at the stem, or stem blocks can be used. Install one deck plate amidships in each pontoon and two deck plates in the main hull.

The curved cockpit-seat supports are laminated by gluing together three strips of $\frac{3}{4}$ x 3-in. spruce. Make a full-sized pattern from dimensions given in Fig. 8 and bend supports in a jig formed by wood.

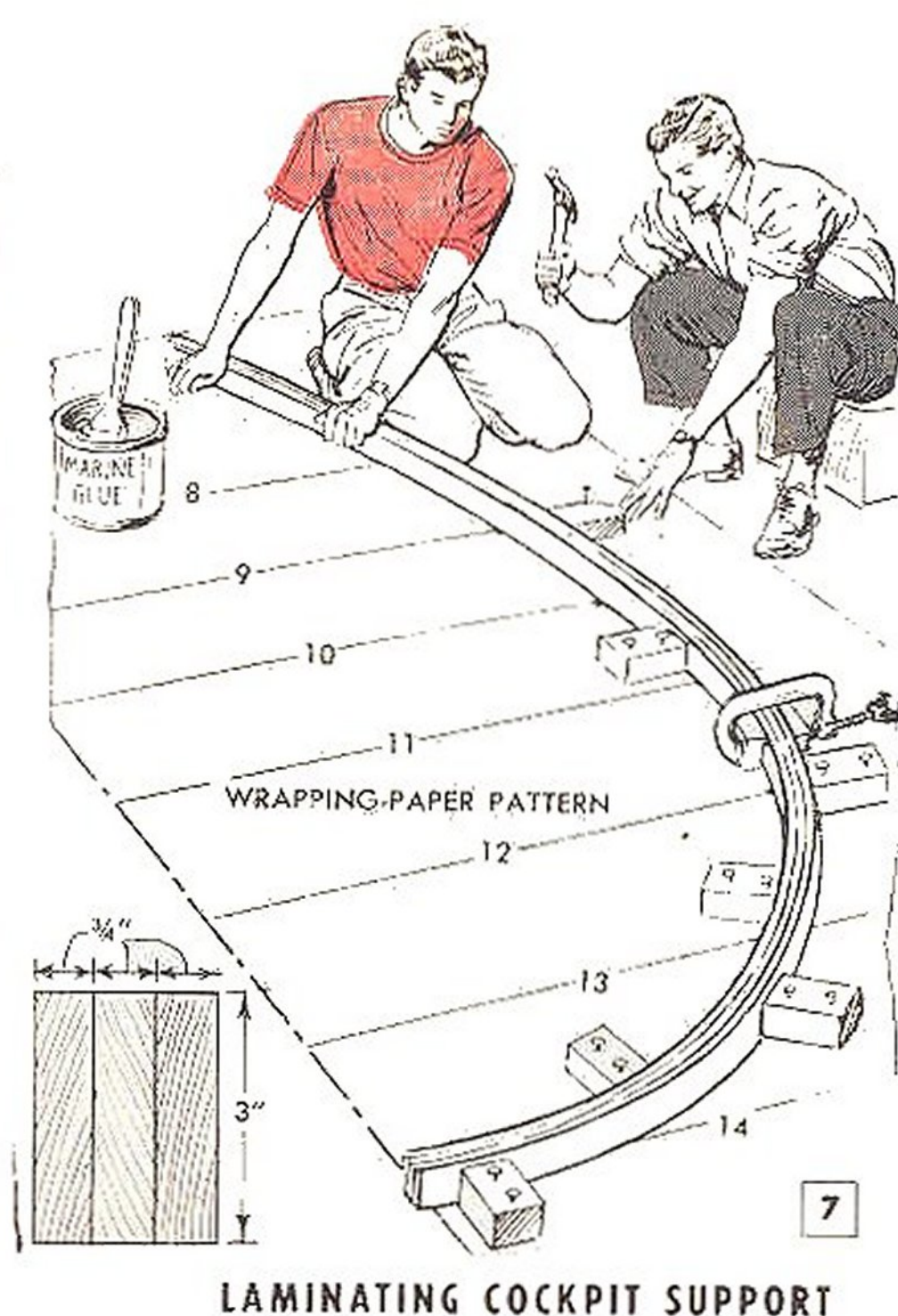

LAMINATING COCKPIT SUPPORT

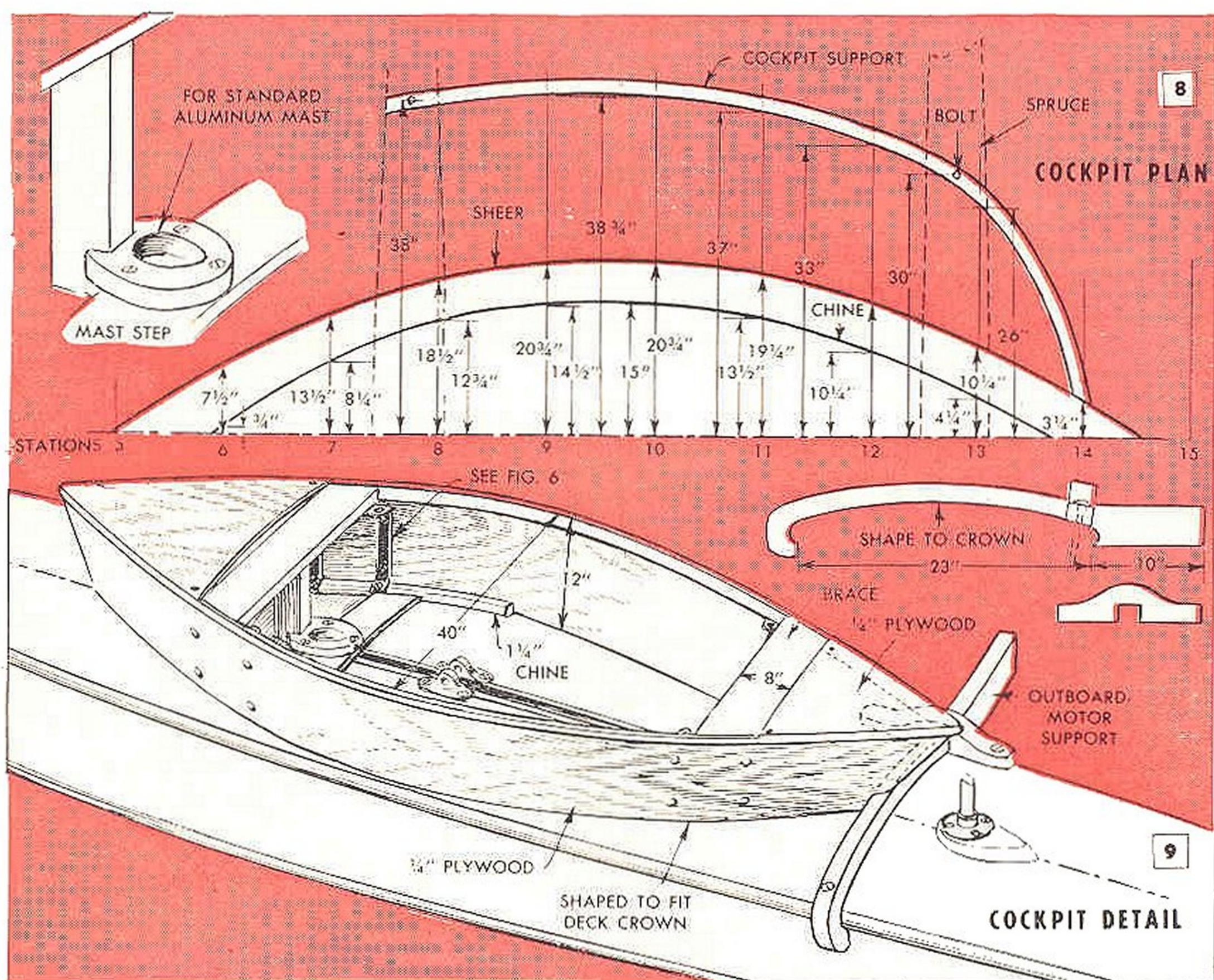

COCKPIT PLAN

COCKPIT DETAIL

10 TABLE OF OFFSETS FOR PONTOONS (DIMENSIONS IN INCHES)

STATION	1	2	3	4	5	6	7	8	9	10	11	12	13	14
TO INNER SIDE BOTTOM AND DECK	1 1/8	1 7/8	2 5/8	3 3/8	3 3/4	4 1/8	4 1/2	4 7/8	4 7/8	4 7/8	4 7/8	4 7/8	4 7/8	4 7/8
TO OUTER SIDE BOTTOM AND DECK	2 1/4	4 1/8	5 1/4	6	6 1/4	6 1/2	6 1/2	6 1/2	6 1/4	6 1/4	6	6	6	6
FREEBOARD	6 7/8	9 1/4	11 1/8	11 1/4	11 1/4	11 1/8	10 1/2	9 3/4	8 3/8	6 7/8	4 7/8	4 1/8	2 1/4	3/4
RISE OF CHINE FLOOR TO BOTTOM	6 1/2	4 1/4	2 1/2	1 3/4	3/4	1/2	1/4	0						

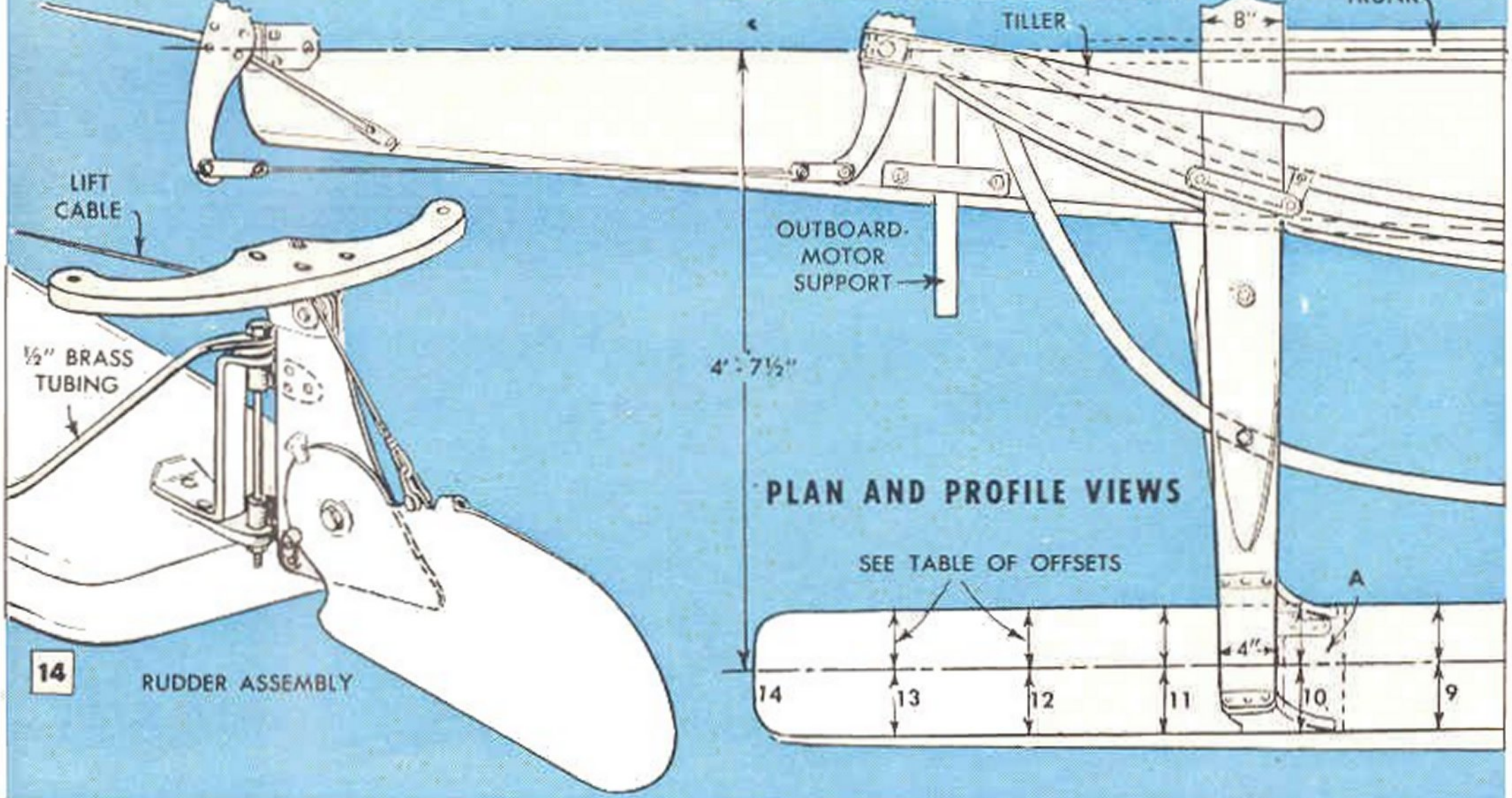
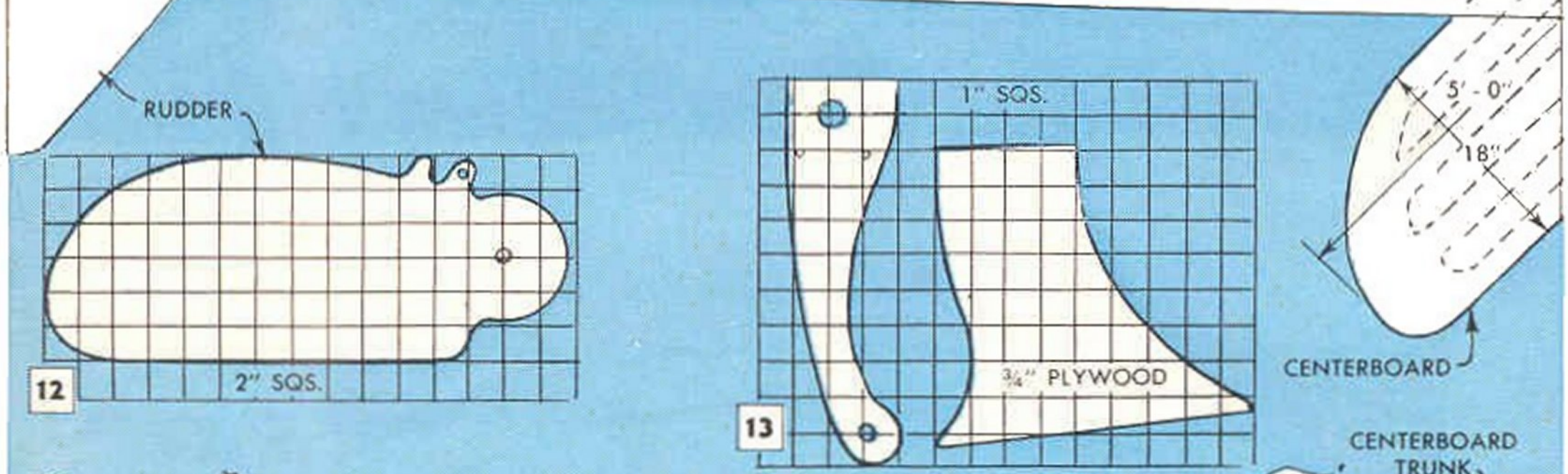
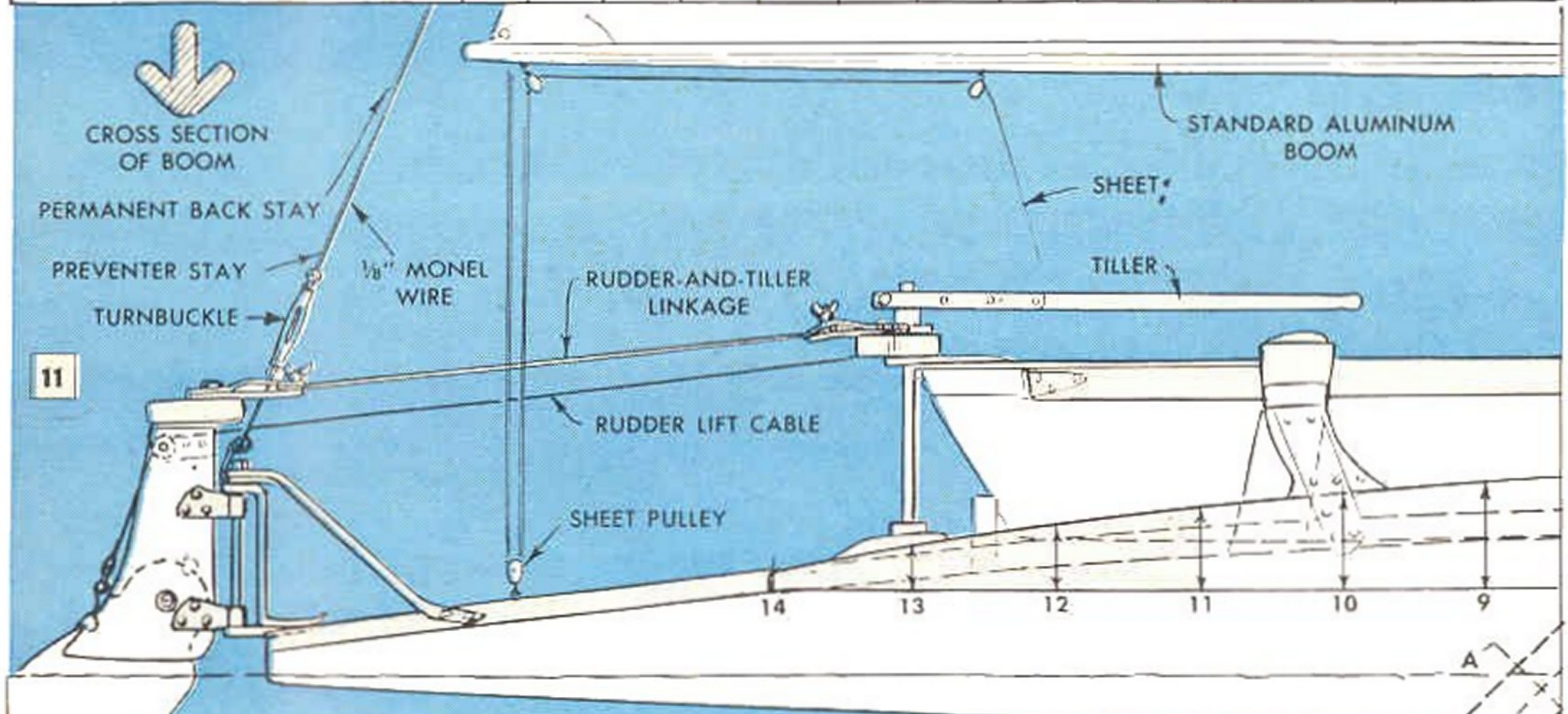

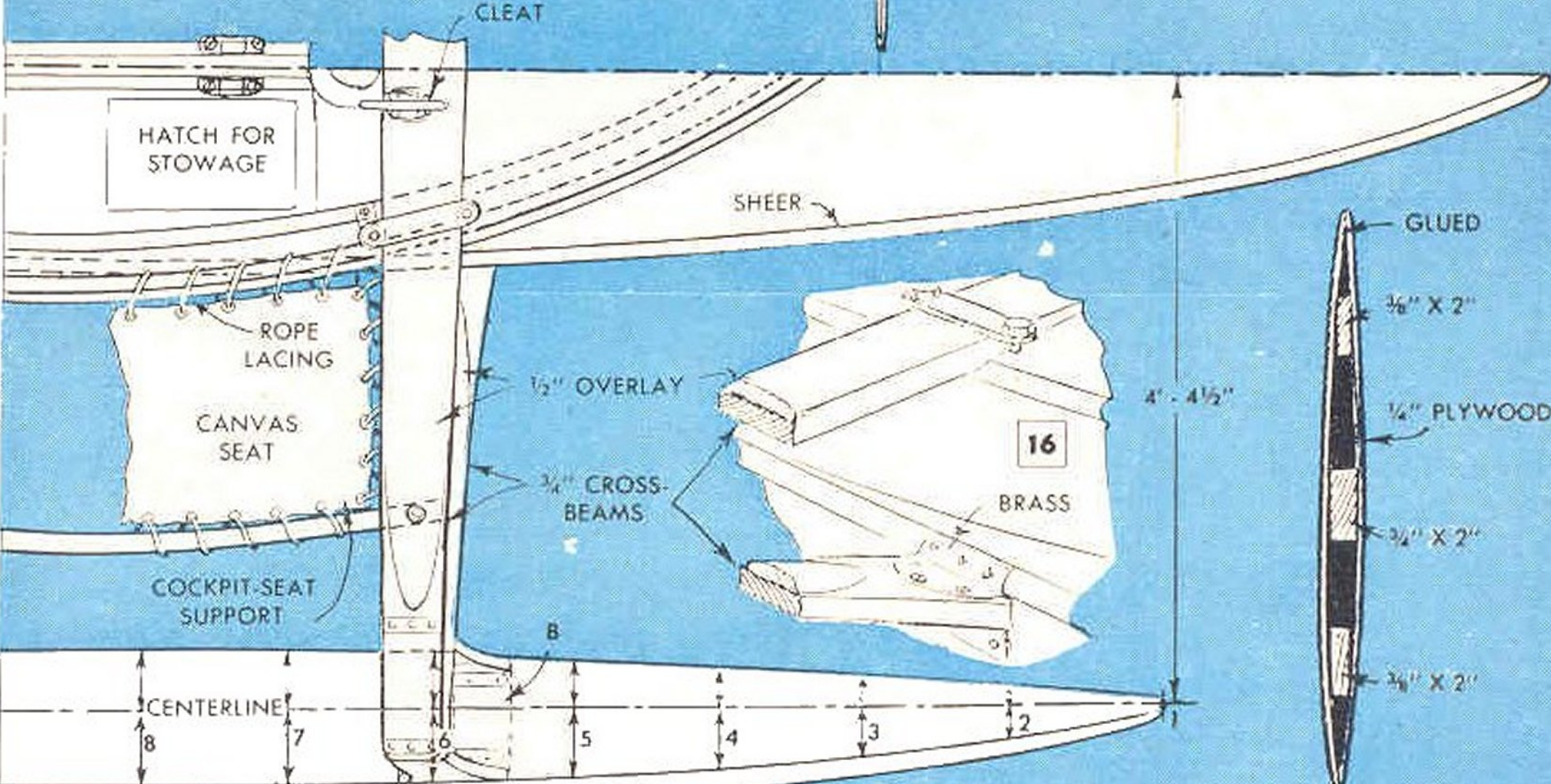
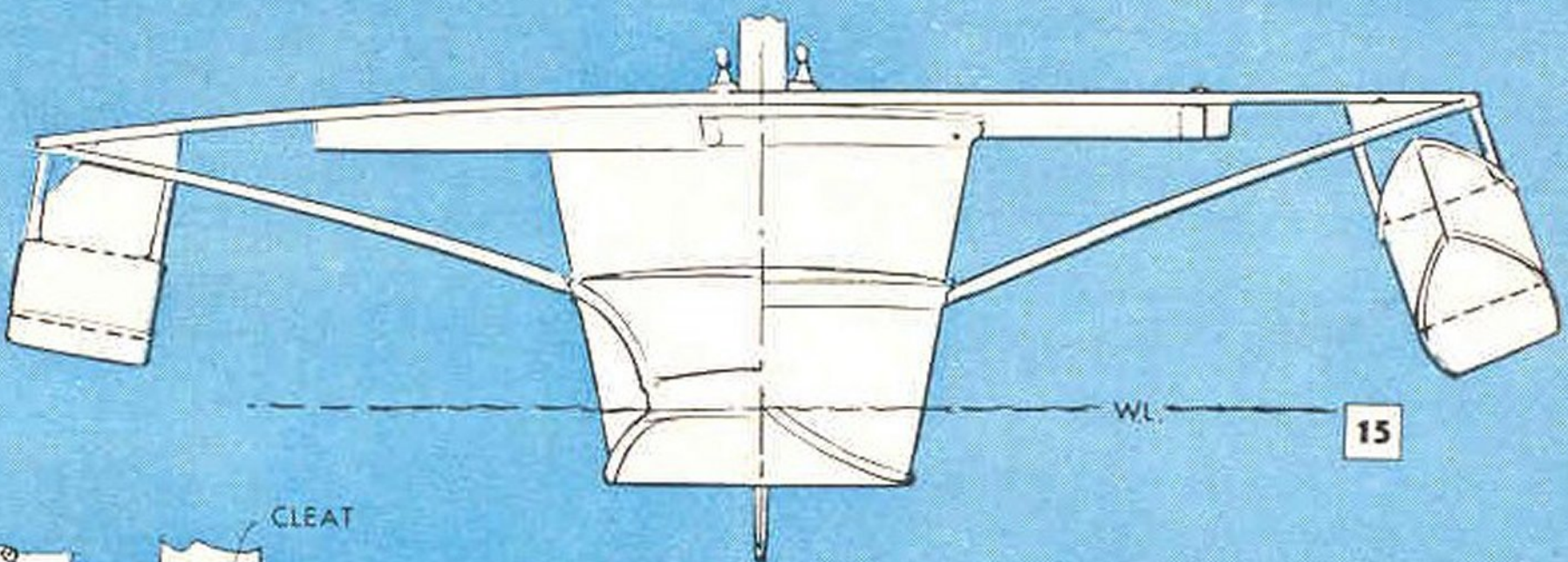
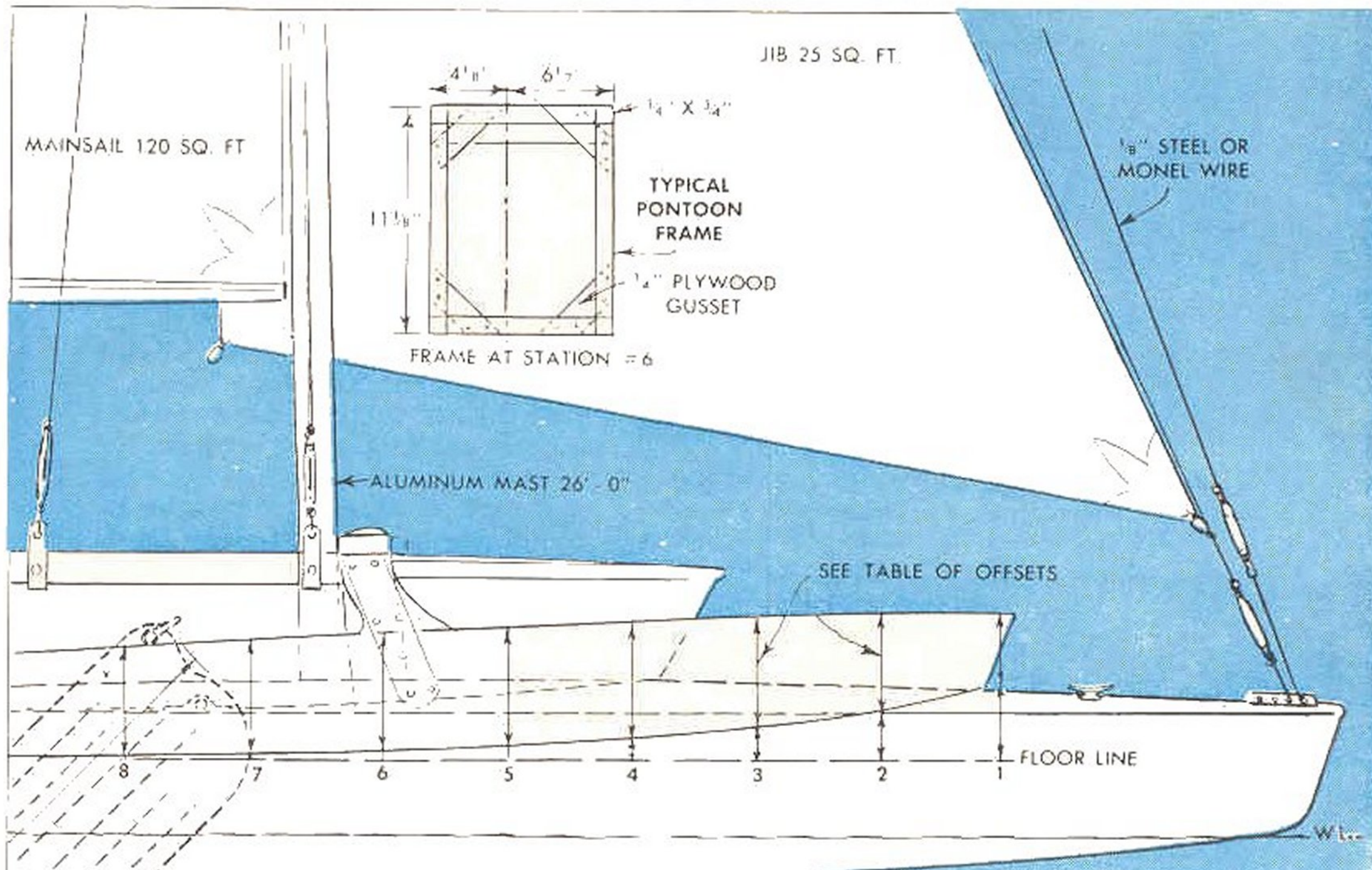

CENTERBOARD SECTION A-A

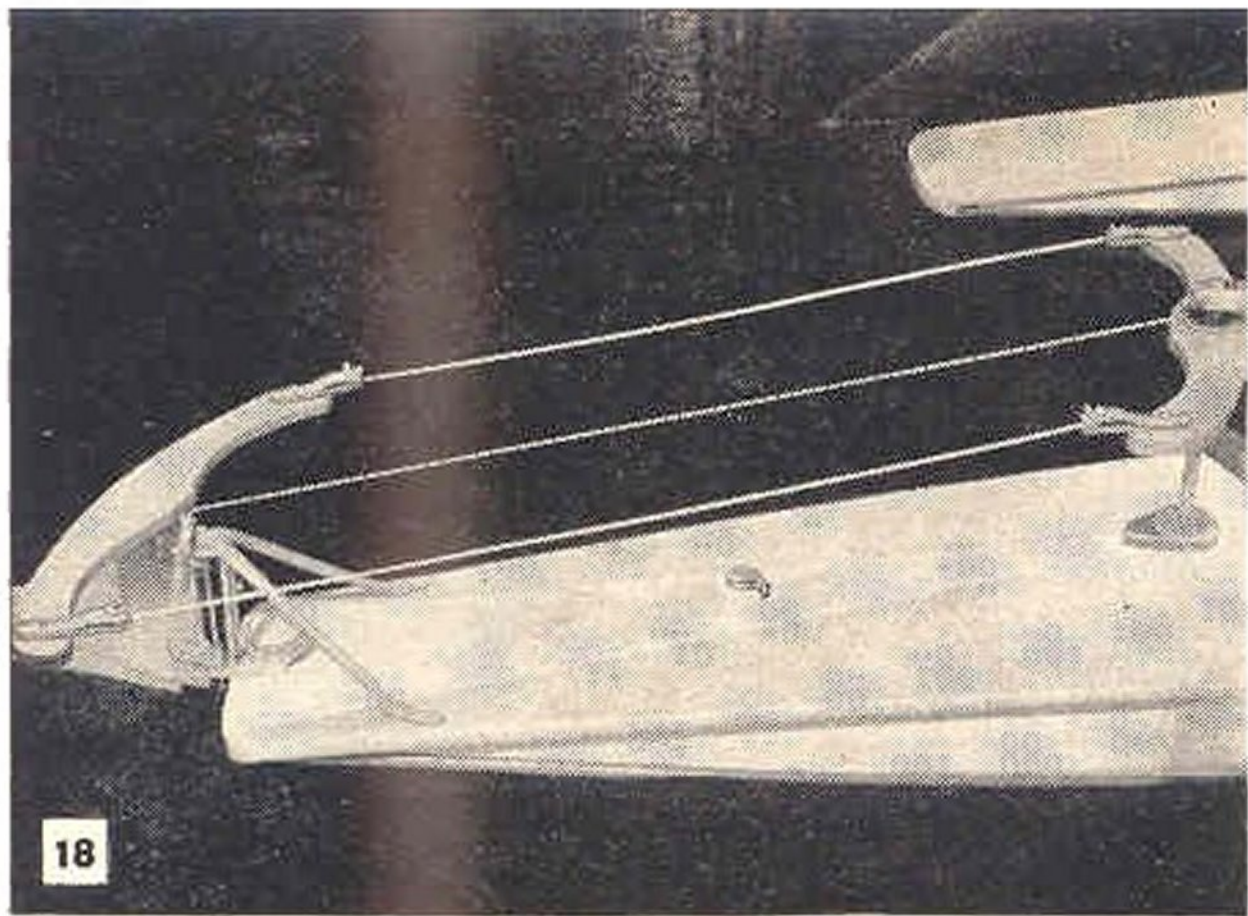

18

Photo above illustrates a typical steering assembly. Folding rudder is raised or lowered from the cockpit with the cable which is visible midway between the rudder-and-tiller linkage

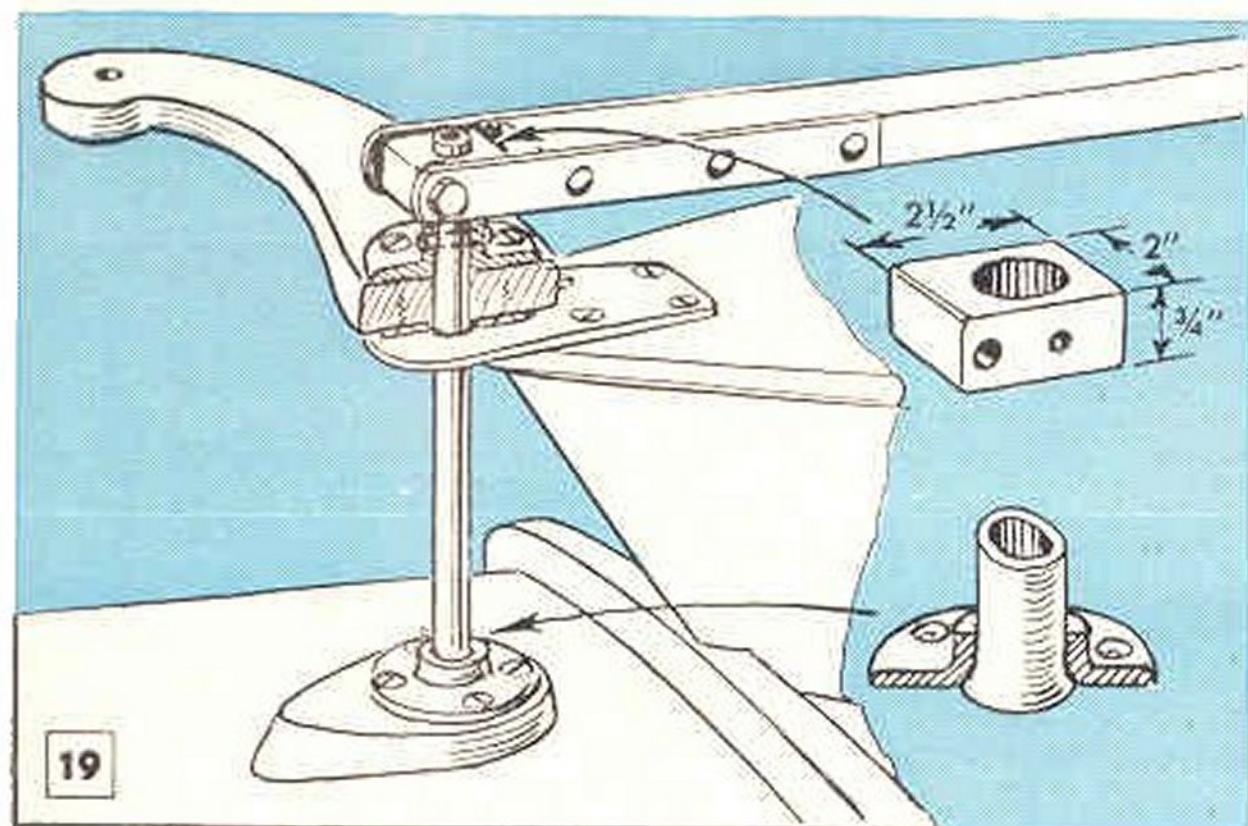

19

tacking wooden blocks to the floor as in Fig. 7. Install the pontoon crossbeams as shown in Figs. 6, 15, 16 and 17, and bolt each cockpit-seat support to the underside of the upper crossbeam members, fastening the inner end of the support to the side of the cockpit with screws and glue. Fig. 5 pictures the pontoons and cockpit completely assembled with the canvas seats laced in place. The rope lacing is passed over the cockpit gunwales and through holes drilled in the sides. At the crossbeams, the rope is passed through notched cleats which are screwed to the undersides of the beams.

The centerboard is made as shown in Fig. 11 and the right-hand detail of Fig. 17. Edges of the plywood sides are glued and nailed together all around. After assembly, the upper end of the centerboard is drilled for a pivot bolt and hoisting shackle. The mast step is installed directly over a frame fore of the centerboard trunk, as in Figs. 8 and 9.

The folding rudder can be cut from galvanized steel or 1/2-in. plywood as in the squared pattern, Fig. 12. The steering arms for both rudder and tiller ends of the link-

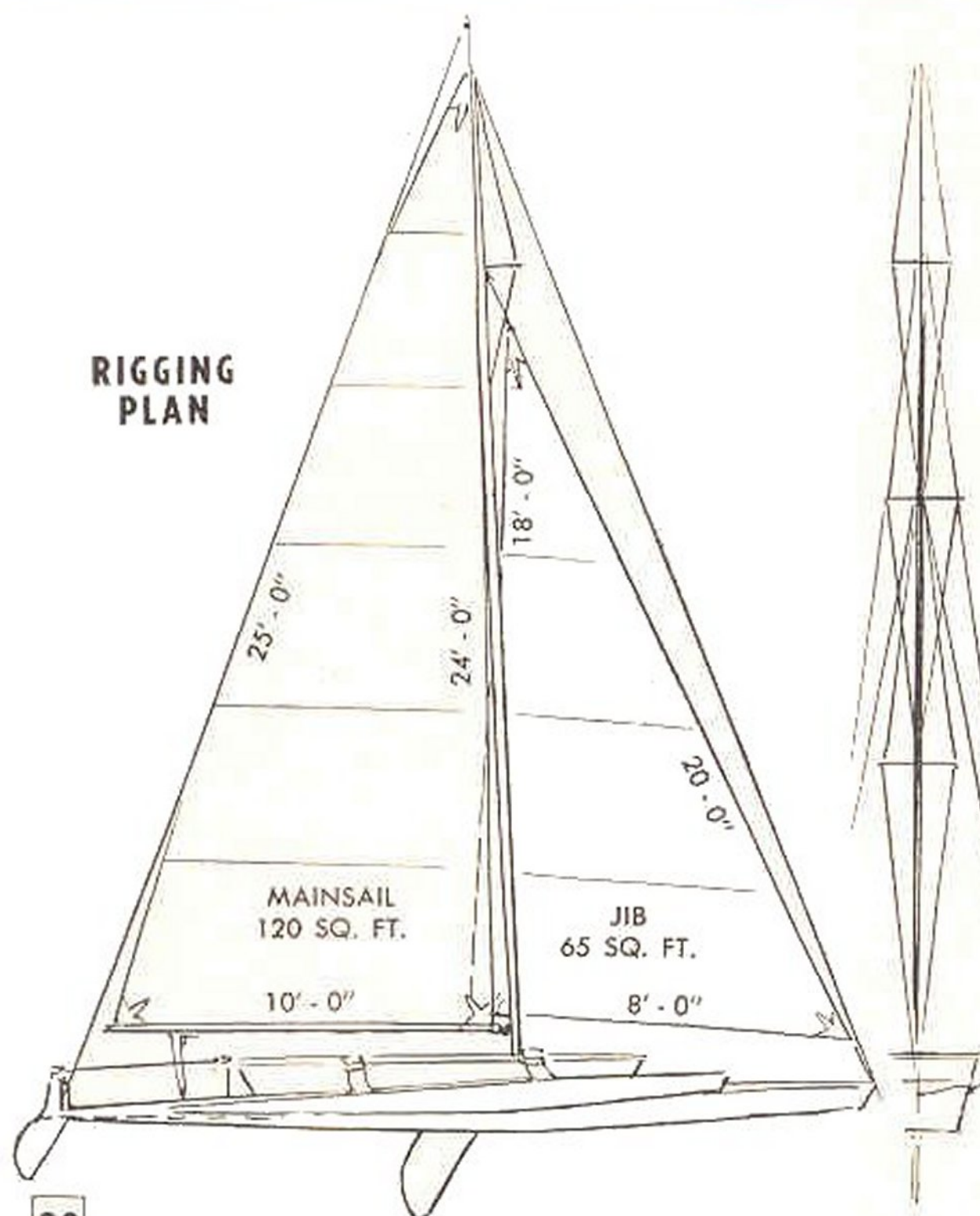

RIGGING PLAN

20

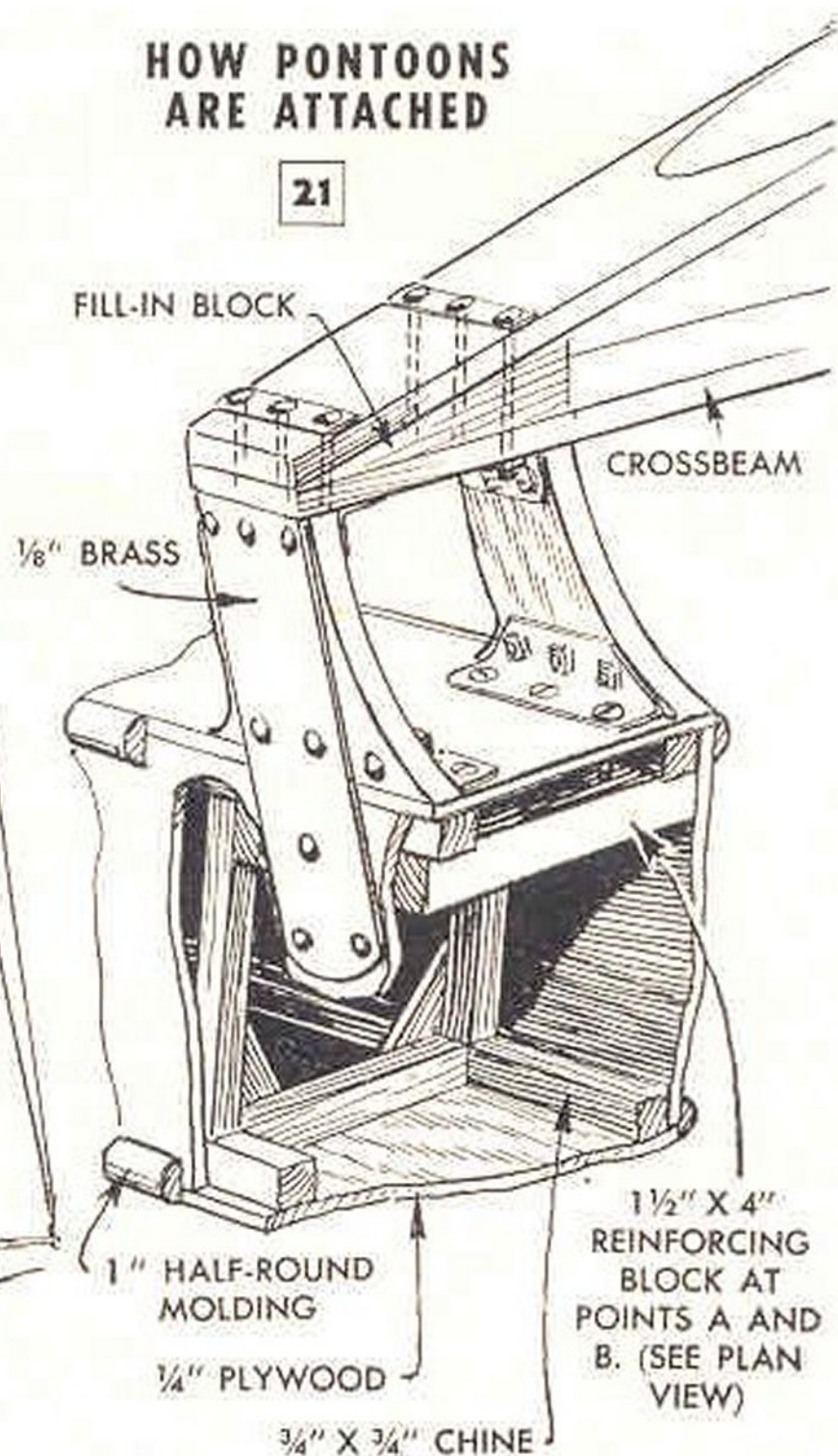

HOW PONTOONS ARE ATTACHED

21

age are cut as in Fig. 13, which also gives the pattern for the $\frac{3}{4}$ -in.-plywood pontoon hangers. The rudder is assembled and then mounted on the hull with a brass bracket braced with tubing, Figs. 11 and 14. The rudder-and-tiller assembly is pictured in Fig. 18. The tiller arm is pivoted on a length of brass tubing as in Fig. 19, the lower end of the tubing being flared to lock it in a brass flange. Note that the tubing is pinned to a pivot block at the top and to a brass flange just below the block. The tiller itself is bolted to the pivot block and the flange is screwed to the top of the tiller arm, as indicated.

All wooden surfaces of Trimaran should be sanded smooth before painting, and then a copper-base wood preservative applied. Follow the preservative with two or three coats of marine paint in the desired color and apply antifouling bottom paint to the area below the waterline.

Fig. 20 shows the general rigging plan and sail sizes. A standard 26-ft. aluminum mast may be used, or one can be made of Sitka spruce. A pear-shaped cross section is recommended for the wooden mast, tapering from 3 in. at the top to 5 in. at the middle and then to 4 in. at the step.

10 TABLE OF OFFSETS FOR PONTOONS (DIMENSIONS IN INCHES)

STATION	1	2	3	4	5	6	7	8	9	10	11	12	13	14
TO INNER SIDE BOTTOM AND DECK	1 1/8	1 7/8	2 5/8	3 3/8	3 3/4	4 1/8	4 1/2	4 7/8	4 7/8	4 7/8	4 7/8	4 7/8	4 7/8	4 7/8
TO OUTER SIDE BOTTOM AND DECK	2 1/4	4 1/8	5 1/4	6	6 1/4	6 1/2	6 1/2	6 1/2	6 1/4	6	6	6	6	6
FREEBOARD	6 7/8	9 1/4	11 1/8	11 1/4	11 1/4	11 1/4	10 1/2	9 3/4	8 3/8	6 7/8	4 7/8	4 1/8	2 1/4	3/4
RISE OF CHINE FLOOR TO BOTTOM	6 1/2	4 1/4	2 1/2	1 3/4	3/4	1/2	1/4	0						

